

Instructions manual



OilMatic Pro / 230 V AC

EN Alarm system
for oil-water separators



OilMatic

1	Description	3
2	Mounting and start-up	4
3	Wiring	5
4	Startup - tests	7
5	Alarm synoptic Diagrams	7
6	Alarm signals	10
7	Audible alarms	10
8	Test mode	11
9	Maintenance	11
10	Precaution	11
11	Technical Features	12

Safety Precautions

Fitting, wiring, initial start-up and maintenance operations must be done by trained technicians.

All European and local rules for electrical instruments must be respected.

The device may only be connected to intrinsically safe measuring circuits which comply with the specifications included in the technical data and on the serial plate.

The device must be disconnected from all sources of power during installation and maintenance work.

The device may only be operated under the conditions specified in the operating instructions.

Respect all recommendations, for installation and mounting of Ex devices, from standards EN60079-14 and EN60079 CENELEC.

The device should not be modified or completed with anything.

All cables to connect the sensor must be out of any place where electrostatic risk exists.

Important: The OilMatic Pro system must be fitted according to technical instructions.

1 DESCRIPTION

EN Designed for the monitoring of hydrocarbon fluids separators, the converter nivo il may be connected to 1, 2, or 3 sensors.

Hydrocarbon fluid layer thickness sensor to detect when the maximum thickness is reached.

Overfill sensor to detect when the fluids are on the highest level; this can occur in case of dysfunction of a filter, when a float-valve closes to prevent an overfilling, when the level of fluid is too high.

Sludge layer sensor to alarm when maintenance is necessary.

Detection of sludge maximal level, as soon as the sludge reaches the sensor, the alarm is switched on.

The 3 sensors may be connected to any input of the alarm device nivo il. any combination of the sensors can be wired. t he instrument recognizes automatically the sensor type. a Led indicates the sensor type on the diagram on the front board. When an input is not wired, the Led is off. t he alarm device OilMatic has a built-in buzzer; it is possible to disable its function by a Dip switch configuration.

2 MOUNTING AND START-UP

The alarm device OilMatic Pro must be mounted out of the Ex area. Cables from safe area and Ex area must pass through pressure glands or wall-ducts IP67 protection according to the standard EN 60529.

Hydrocarbon fluid layer thickness sensor: Fit the sensor such as the sensor tip corresponds to the bottom of the greater layer thickness to detect. The graduated stem (5, 10 and 15 cm marks) makes the adjustment easier.

Overfilling sensor: Fit the sensor such as the sided aperture on the stem corresponds to the alarm level.

Sludge layer sensor: Fit the sensor such as the ends of u probe are 2 cm under the alarming level.

Caution: The sensor may be not subject to move due to turbulences. Do not knock the probe during mounting and maintenance operation.

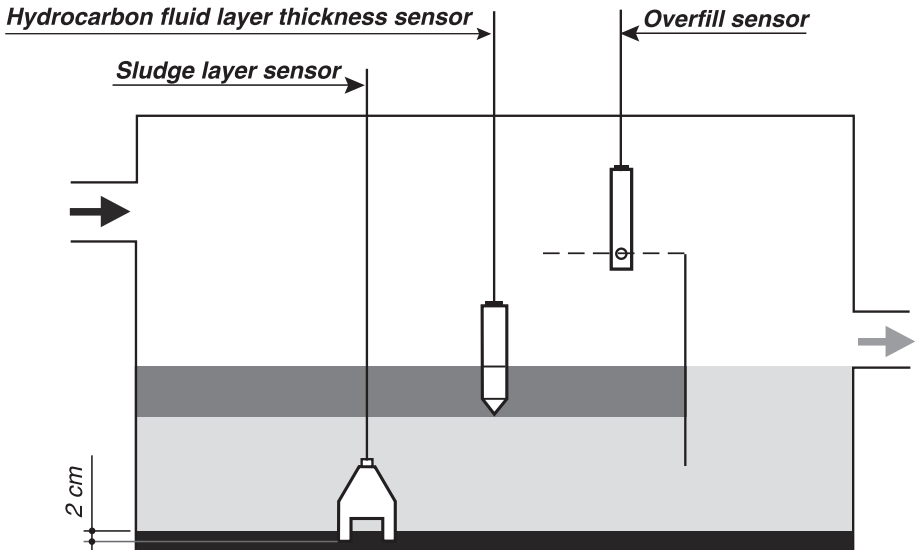

EN

3 WIRING

1°) open the cabinet
and **carefully disconnect the ribbon cable.**

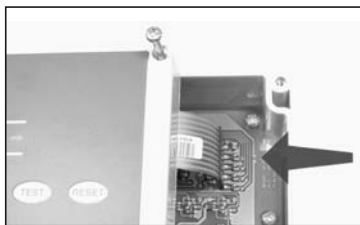

*Conform to the standard rules concerning
Ex area.*

*Electrical circuit with intrinsic safety
components may not be connected to
the ground.*

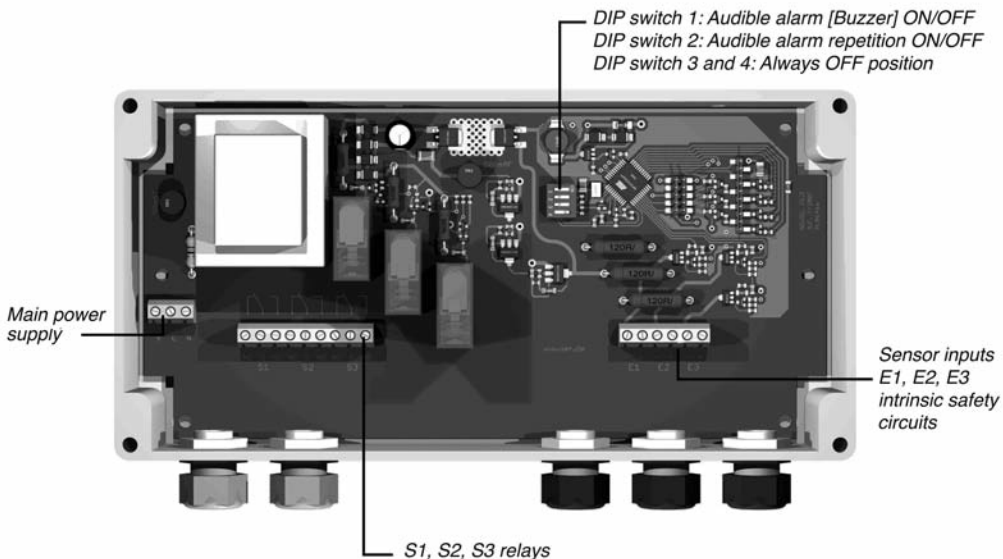

Do not connect the main power until the end of wiring

2°) remove the external sheath on a maximal length of 6 cm and fit on cable terminals.

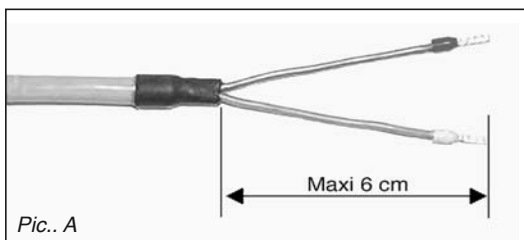

Cable extension

the maximal length of an extension is 300 m.

use the specific cable reference sk-pVc-2x1, at eX certified.

the easier way to extend the cable accordingly with **ATEX** rules, is to use the **CET02** cable coupling (Pic.B), reference nivo il-Jt, suitable to at eX zone **0** category **1**.

the device is delivered with **2 WAGO connectors** (Pic. C) for fast coupling.

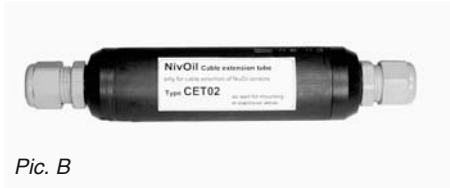

Pic. B



Pic. C

cable cross section: 4 mm² as a maximum

Protection: IP 65 (not for a continuous immersion)

the shield must not be connected.

both ends must be pressed to the limit and pressure cable glands well tightened.

3°) connect the sensors to the control unit nivoil in accordance with the obligations due to ex area, as shown on the drawing.

The measuring loop, as an intrinsic safe circuit, must not be connected to the ground.

connect the control unit to the main power line.

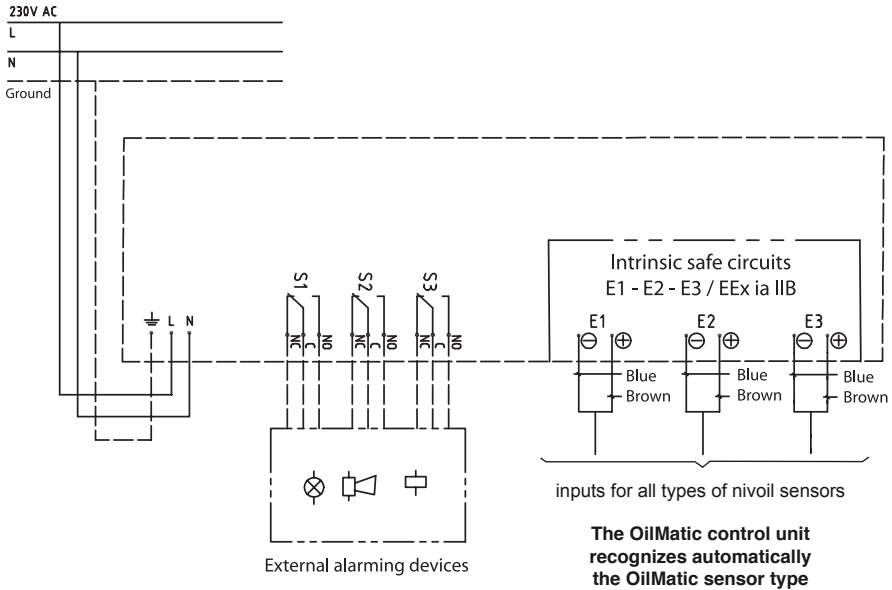

4°) connect back the ribbon cable and close the cabinet.

4 START UP - TESTS

When the OilMatic Pro unit is connected to the main power supply, it begins automatically a self test of each LeD indicators and of the audible alarm (buzzer).

- t est of all sensors connection (*short circuit and broken cable of measuring loops*).
- Detection of sensor type, if the result is positive, the corresponding Led will light on.in case of a defect, the Led will be flashing.

For a non connected channel, the Led keeps off .

During the first start-up, the alarm device OilMatic memorizes the type of sensor connected to a channel.

- When the test mode is activated, an audible signal is sent if everything is correct (*the factory configuration is without sensors*).
- When you connect a new sensor on a free channel, the alarm device nivoil will identify and memorize it as soon as you switch on the power.

If a sensor is removed, the corresponding light will be flashing (default alarm).

proceed to a **reset**, pressing the **RESET button at least 5 seconds** to confirm the removal of the sensor.

- When a sensor is removed without a complete res et , then all the Led will be flashing to alarm this default status.

5 ALARM SYNOPTIC DIAGRAMS

For hydrocarbon fluid layer thickness and overfilling sensors (DIP3 = OFF)

Note: to avoid false alarms a 10 seconds delay is factory set up.

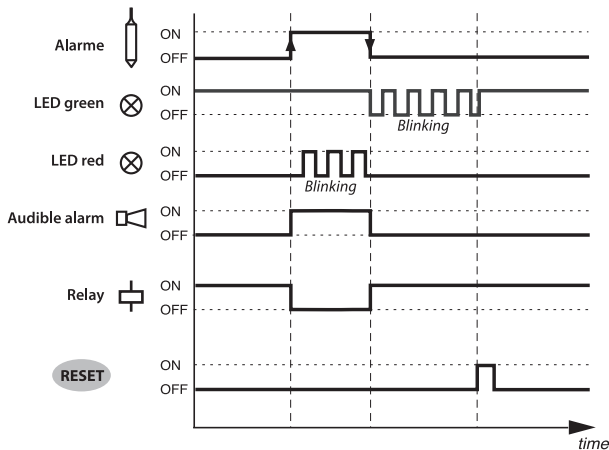

Event 1: Waves on the fluid surface.
Status alarm is ON and resets by itself.
The green LED is then reseted

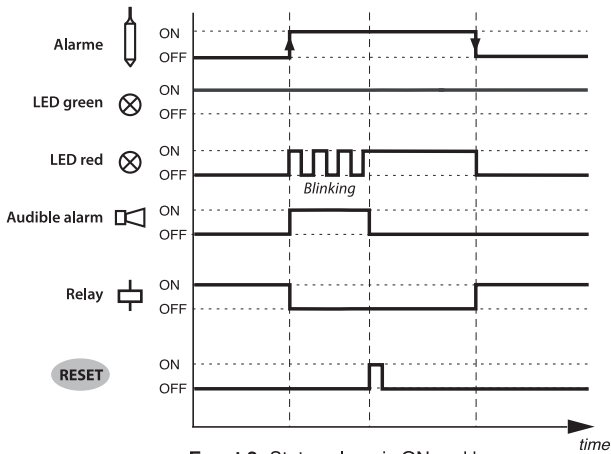

Event 2: Status alarm is ON and keeps on. Press RESET button, to reset the alarm. The red LED shuts OFF when the alarm origin disappears.

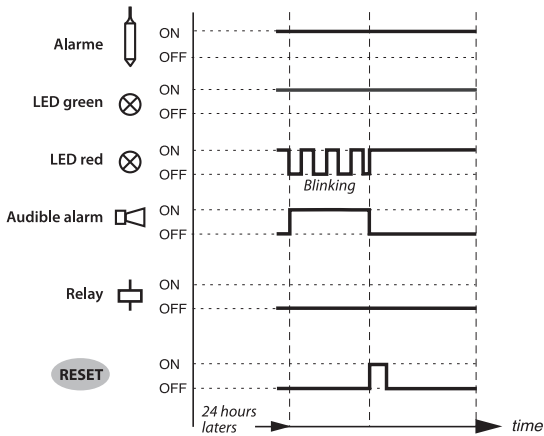

Event 3: Alarm have been on reset, but default origin still exists. After 24 hours the alarm set ON again and red LED is blinking.

Repeat alarm function: the alarm repetition function is disabled or activated with the Dip switch 2. When Dip 2 is in position "on" the alarm will repeat again 24 hours after the first event, if the alarm event is not corrected.

These functions correspond to 2 signalization modes, i.e.:

Test mode, when starting up the system, alarms actuated without delay for a rapid test and diagnostic of the system probe + cable + alarm unit.

Monitoring mode, during normal operation condition, a delay of 15 min applies to avoid false alarms (due to turbulences for instance).

TEST mode

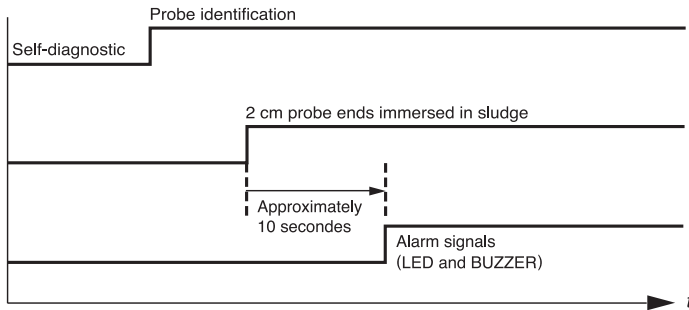

the test could be completed with the probe outside the separator and totally immersed in water. after the auto diagnostic sequence, the control unit recognized the sludge probe and will:

- alarming when the probe ends are in the air
- Or
- when probe ends are inside 1 cm or 2 cm inside sludges (*sand, soils etc.*)

When the test is completed, fit back the probe inside the separator, immersed in water. Fifteen minutes would be necessary before the detection may be operating (*monitoring mode*).

MONITORING mode

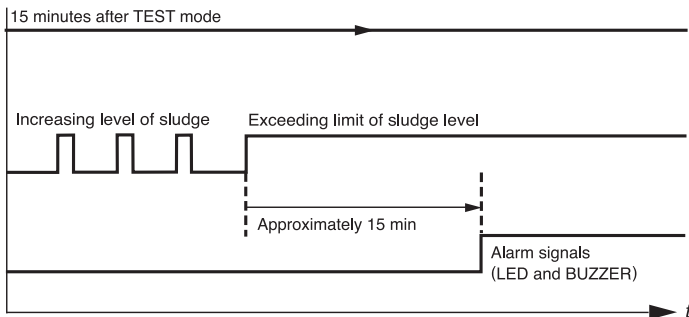

When you immersed the probe in water inside the separator, 15 min are necessary for the OilMatic Pro unit to validate the system conditions.

the OilMatic will give an alarm when:

- sludge level will cover about 1 cm of ends probe and at least during 20 min (approximately). the delay avoids false alarms; the alarm can be reseted when the cause is corrected.

The alarm synoptic diagrams for the sludge probe are identical to the diagrams for hydrocarbon fluid layer thickness and overfilling sensors

6 ALARM SIGNALS

Initial start up

<i>After the auto-diagnostic sequence</i>	
short circuit in the measuring loop	- all the green Led are blinking - audible alarm is on - relays are off
measuring loop cable is broken	- all the Led are shut off - audible alarm is shut off - relays are off
Wrong polarity on sensor wiring	- all the Led are shut off - audible alarm is shut off - relays are off

After a while, when the device is operating

short circuit in the measuring loop and measuring loop cable is broken	- the green Led corresponding to the channel is blinking - audible alarm is on - the relay is off
--	---

The green LED is blinking and the relay status keeps OFF until the default origin is corrected. The audible alarm is cleared by pressing "RESET" button.

When wiring is wrong polarity, or when sensor is disconnected

After correcting the failure , switch on the power; then press the "r e s e t " button during 5 seconds.	- t ype sensors are detected and then displayed..
---	---

7 AUDIBLE ALARM

to disable the audible alarm use the Dip switch 1 inside the cabinet. therefore the alarm status is indicated by the Led (only).

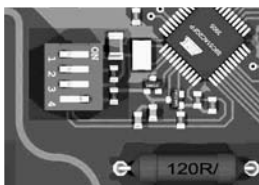

Caution !

Disconnect from the main power before opening the cabinet

8 TEST MODE

the alarm device Oilmatic Pro runs an auto-diagnostic sequence each time you need to test the system:

- press the "test" button (at least 1 second)
- auto-diagnostic routine begins, Led are blinking (Led test)
- the buzzer is switch on (audible alarm test)
- check out of sensor parameters (test of sensor type, short-circuit, broken cable)

Positive test: Corresponding LED are ON

Negative test: corresponding green Led are blinking

9 MAINTENANCE

the alarm device OilMatic and OilMatic sensors do not require any maintenance operation in normal operation.

After an alarm occurred, the sensors must be cleaned as the separator is drained.
to clean out a sensor use a wetted rag, with a house cleaning and degreasing liquid.

10 PRECAUTION

Hydrocarbon fluid layer thickness sensor

thickness detection cannot be performed properly in contact with existing chemical substances such as emulsifiers and surface active wetting agents (de-tergent). the sensor must be in contact only with liquids compatible with polyethylene.

11 TECHNICAL FEATURES

OilMatic Pro

main power supply:	230 V - 50 hz
power consumption:	9 Va approximately (3 sensors connected)
housing protection:	ip65, according en 60529
temperature limits:	-20...+60°C
sensor inputs:	3 inputs with automatic sensor type detection for hydrocarbon fluids layer thickness, overfill level, sludge layer level
monitoring:	the alarm device nivoil has an auto-diagnostic of measuring loop. an alarm signal occurs in case of dysfunction due to a short circuit or a broken cable.
Display and signals:	1 function signal LeD (green) on each channel 1 alarm signal LeD (red) on each channel built-in audible alarm, disabled by Dip switch configuration
Front panel:	2 push buttons for diagnostic test and alarm clearance
outputs:	3 relay outputs, 230 V ac, 3a, potential free change over contacts

Ex protection class: Ex II (1) G [Ex ia] IIB (Intrinsic safety)
ATEX certificate: **BVS 07 ATEX E 090**

CE marks: according to **EC** directives,
Low Voltage guidelines: **RL 2006/95/EG & RL93/68/EWG**,
emV guidelines: **RL 89/336/EWG** (en 61326)

ATEX: rL 94/9/eg (ATEX 95)
EN 60079-0 (General requirements)
EN 60079-11 (Intrinsic safety)
EN 60079-26 (Group II; category 1G)

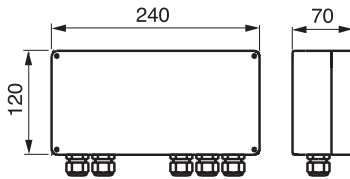

- (1) the alarm device OilMatic must be mounted in safe area
- (2) concerning the intrinsic safety parameters [u_o , i_o , p_o and c_o , L_o], please report to the ATEX certificate.

OilMatic-OP/10 – Hydrocarbon fluid layer thickness sensor

(Only for use with an alarm device NivOil)

sensor type:	capacitive, high frequency
Wetted parts:	antistatic pe stem; stainless steel end probe
cable:	elastomer resistant to oils and hydrocarbon fluids, blue colour; wires 2x1mm ² , connections to the alarm device n ivo il on screw connectors; 10 m long cable (max length is 300 m)
protection:	ip68 acc. en 60529
temperature limits:	-20...+60°C

Ex protection class: **II 1 G Ex ia IIB T4** (Intrinsic safety)
ATEX certificate: **BVS 07 ATEX E 091X**

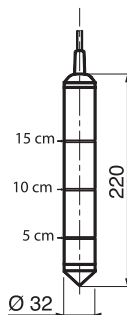

OilMatic-HP/10 – Overfilling sensor

(Only for use with an alarm device NivOil)

sensor type:	ptc sensor
Wetted parts:	antistatic pe stem; stainless steel end sensor
cable:	elastomer resistant to oils and hydrocarbon fluids, blue colour; wires 2x1mm ² , connections to the alarm device n ivo il on screw connectors; 10 m long cable (max length is 300 m)
protection:	ip68 acc. en 60529
temperature limits:	-20...+60°C

Ex protection class: **II 1 G Ex ia IIB T3** (Intrinsic safety)
ATEX certificate: **BVS 07 ATEX E 092X**

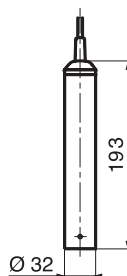

OilMatic-SP/10 – Sludge layer sensor

(Only for use with an alarm device NivOil)

sensor type:	ultrasonic detection type
Wetted parts:	pVc
cable:	elastomer resistant to oils and hydrocarbon fluids, blue colour; wires 2x1mm ² , connections to the alarm device n ivo il on screw connectors; 10 m long cable (max length is 300 m)
protection:	ip68 acc. en 60529
temperature limits:	-20...+60°C

Ex protection class: **II 1 G Ex ia IIB T4** (Intrinsic safety)
ATEX certificate: **BVS 09 ATEX E 021X**

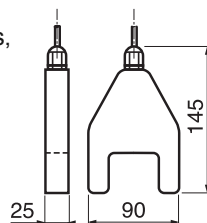

- (1) these three probes could be mounted in zone 0
- (2) concerning the intrinsic safety parameters [u_i, i_i, p_i and c_i, L_i], please report to the ATEX certificate of each probe.



www.oilmatic.fi

Manufacturer:

bamo mesures sas
22, rue de la Voie des bans
z.i. de la gare
95100 argenteuil

tél : (+33) 01 30 25 83 20
Fax : (+33) 01 34 10 16 05

e-mail : info@bamo.fr

Web : www.bamo.fr – www.bamo.eu

bamo-ier gmbh
pirnaer straÙe 24 – D-68309 mannheim telefon:
+49 (0)621-842240
t elefax: +49 (0)621-8422490

e-mail: info@bamo.de
internet: www.bamo.de